

# SINGLE UNIT

1 POST - 3 BOXES MAX

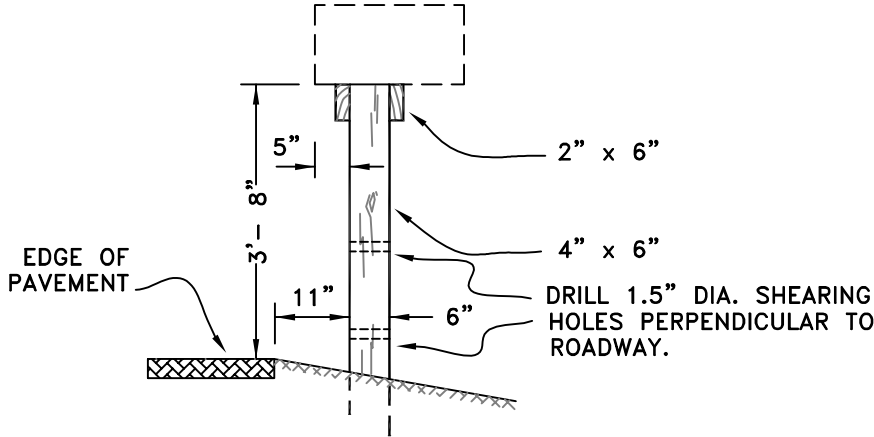
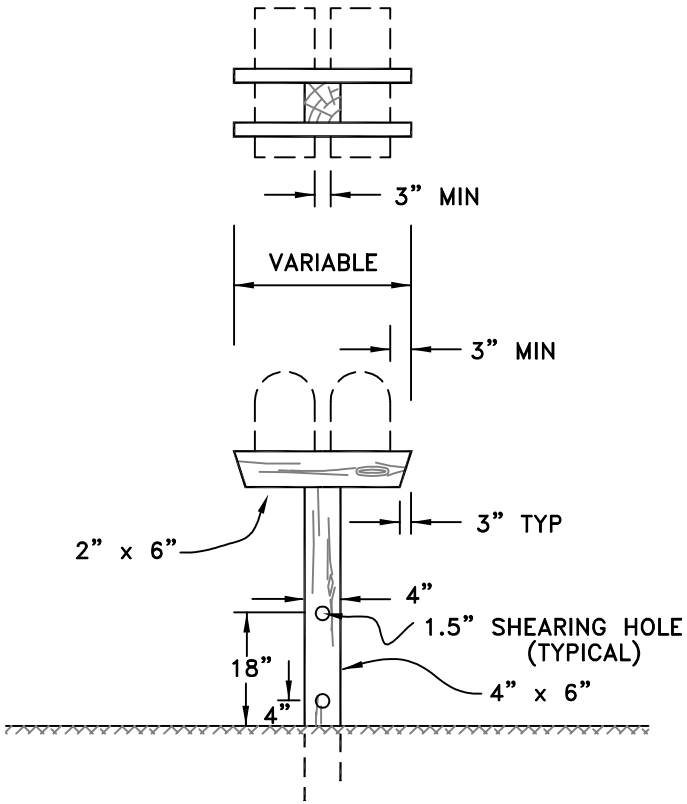

**NOTES:**

1. ALL LUMBER SHALL BE PRESSURE TREATED DOUGLAS FIR, WESTERN HEMLOCK, OR WESTERN PINE.
2. ALL POSTS TO BE SET AT A MINIMUM OF 24" BELOW SURFACE OF THE GROUND.
3. TREAT CUT OR DRILLED PRESSURE TREATED LUMBER WITH JASCO TERMIN 8 GREEN PRESERVATIVE OR APPROVED EQUIVALENT.
4. REINSTALL NEWSPAPER BOXES ON NEW MAILBOX POST OR AS DIRECTED.

**JACKSON COUNTY ROADS**  
 DALE W. PETRASEK, P.E.  
 COUNTY ENGINEER

Date	By	Revision
1/2002	TMJ	
03/2003	TCM	Add note #4

**MAILBOX STAND-SINGLE**  
 I:\Engineering\Library\County\English\MailboxSingle.dwg  
**SHEET 1 OF 1 SCALE: NO SCALE**



**JACKSON COUNTY**  
*Roads*