

TYPE II BARRICADE
ALTERNATE W/TUBULAR
MARKERS @ 200'
INTERVALS

TUBULAR MARKERS
PLACED @ 25'
INTERVALS

'ABRUPT EDGE' SIGN
INSTALL AT 500'
INTERVALS

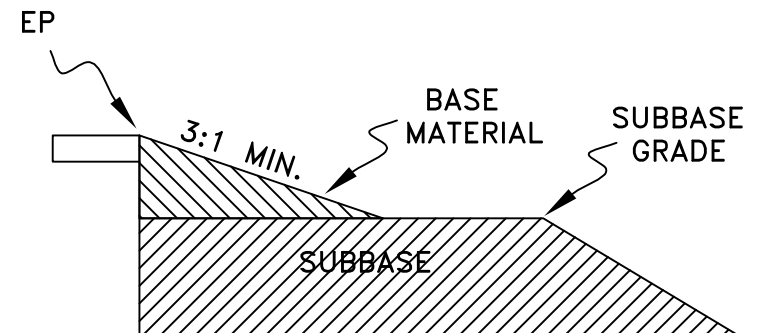
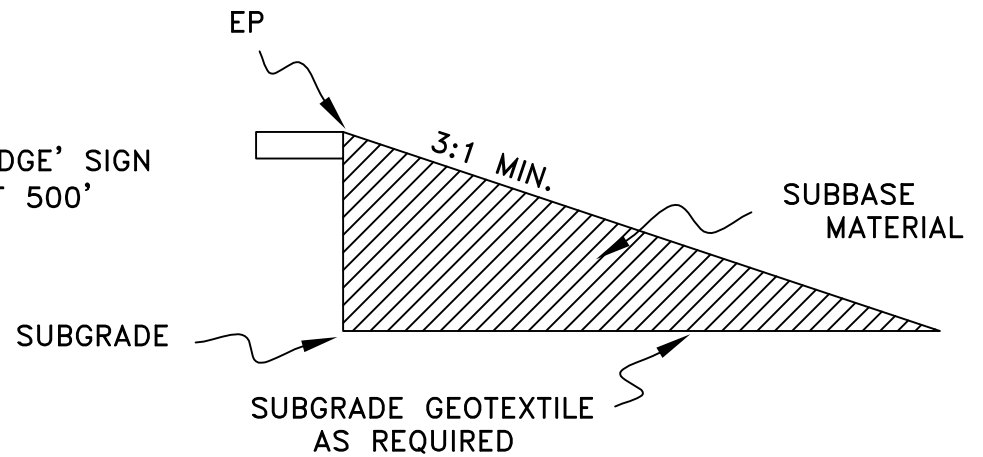
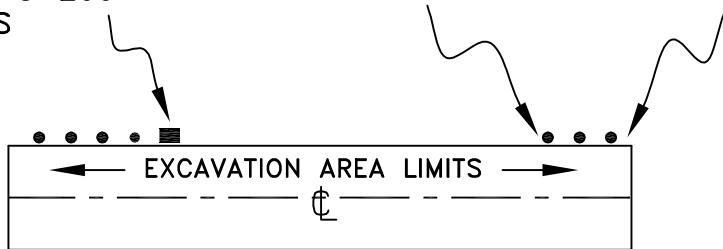

NOTE:

AT THE END OF EACH WORK DAY, BACK FILL PAVEMENT
EDGE EXCAVATIONS TO EXISTING PAVEMENT WITH BASE
OR SUBBASE MATERIAL WITH A MINIMUM 3:1 WEDGE.

DO NOT EXCAVATE ALONG BOTH EDGES OF THE
PAVEMENT ADJACENT TO TRAFFIC AT THE SAME TIME.
BEFORE EXCAVATING AT THE EDGE OF PAVEMENT ON
THE OPPOSITE SIDE OF THE ROADWAY, COMPLETE THE
CONSTRUCTION TO EXISTING PAVEMENT ELEVATION ON
THE SIDE WHICH WAS EXCAVATED FIRST.

JACKSON COUNTY, OREGON
ROADS AND PARKS SERVICES

DALE W. PETRASEK, P.E.
COUNTY ENGINEER

Date	By	Revision
1/2002	TMJ	

ABRUPT EDGE/EXCAVATION
AREA SIGNING

I:\Engineering\Library\County\English\Abrupt edge-Excavation.dwg

SHEET 1 OF 1

SCALE: NO SCALE



**JACKSON
COUNTY**
Roads